

INTRODUCTION

Assembly of the Shoo-fly System is simple and accomplished with only a few tools. No special tools are required. You will need the following: Hammer, Screwdriver, Crescent Wrench, Diagonals and a straight blade.

There are two important steps to be taken prior to starting the assembly:

1. Inventory all items to assure all material and parts are accounted for. If any items are missing contact Shoo-fly to have those items forwarded to you.
2. Read the instructions **completely before** starting to assemble the system. It is important to understand what each unit does and how its function contributes to the entire system.
3. You can also view installation videos on our website at www.shoo-fly.com under the instructions tab.

LIMITED WARRANTY: Shoo-fly warrants the Shoo-fly system for a period of one year from the date of purchase by the original purchaser to be free of manufacturing defects. The system and the insecticide are designed to operate as a unit. The use of other insecticides or liquid through this system **VOIDS** the warranty. We do not warranty systems that are not properly maintained, exposed to elements or neglected.

Thank you for your purchase,

Shoo-fly Staff

Please return the enclosed warranty card to Shoo-fly and fill out information below for your records.

For Your Records

Purchased from: _____

Phone # _____ Date: _____

Insecticide used: _____ Number of Nozzles: _____

COMPLETE NOZZLE

Parts:

Male Branch Tee, 1/4" Nozzle Adapter, Nozzle Tip

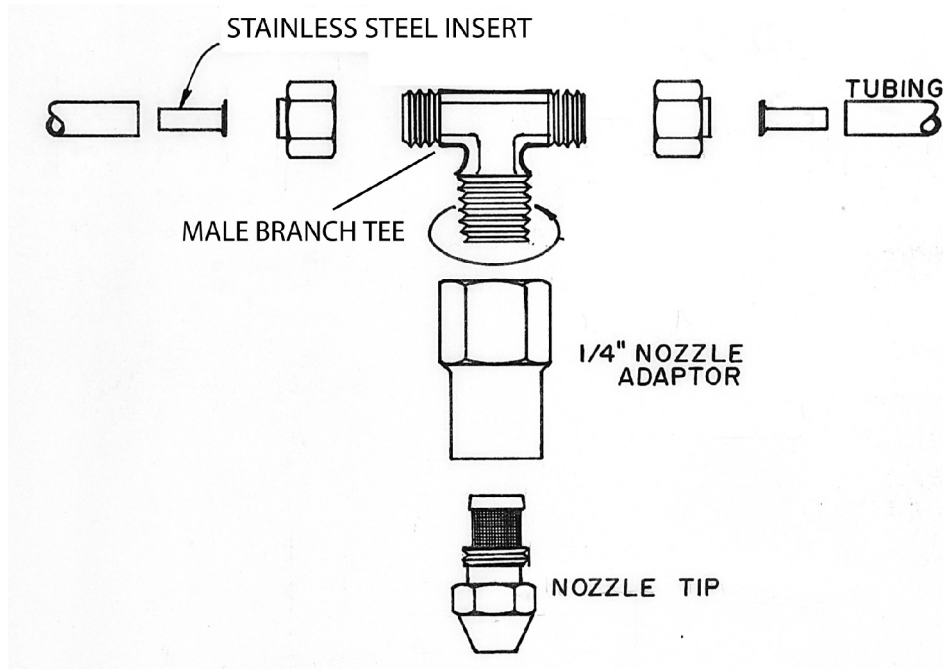

Complete Nozzles usually come pre-assembled. Below are instructions for putting them together.

1. Male Branch Tees usually have orange vibra-seal. If threads are bare, you will need to wrap the threads with teflon tape. Wrap the tape clock wise, in the direction the Nozzle Adapter will be turned when screwed onto the Tee (*if the tape is wrapped in the wrong direction, the tape will come off when screwing on the adaptor*). Be certain to wrap the tape 2x to cover the threads.
2. Screw the hexagonal end of the Nozzle Adapter onto the Male Branch Tee. Do not over-tighten this connection. The fitting will seat before all of the threads are covered.
3. Screw Nozzle Tip into the tubular end of the Nozzle Adapter. Finger tighten then finish with approximately a 3/4 turn with a wrench to seat.
4. A Male Elbow may be used in place of the Male Branch Tee, if you are going to dead end the tubing run.

CONNECTING TUBING & BRASS

Compression Fittings

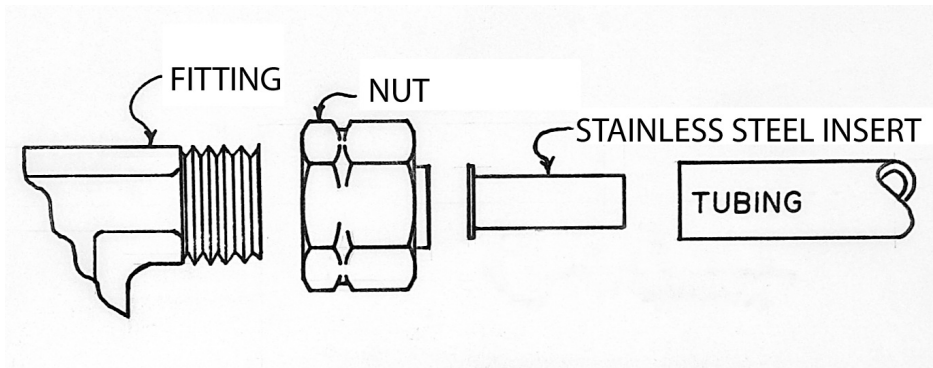

Procedure:

1. Cut the Tubing at a 90 degree angle; slight variation is acceptable.
2. Screw the Nut onto one of the appropriate brass fittings. Finger tighten the Nut.
- 3 Slide a Stainless Steel Insert into the cut end of the Tubing.
4. Push Tubing with the Insert into the Nut. Hold the Tubing against the bottom of the fitting and tighten the Nut approximately 1 to 1.25 turn to seat the Compression fitting.

Re-attaching Nuts with Tubing:

Nuts which have been disconnected from their former fittings and need to be re-attached again, do not need to be screwed down as tightly because the SS Insert has already been seated into the Tubing. Make sure that the insert is still in the end of the fitting. Then screw the Nut down finger tight and use a wrench to tighten approximately 1/2 turn.

Important to note:

- Compression fittings need to be snug so the tubing does not blow out under the pressure of the system. Over tightening can split the Nut. Extras nuts/inserts, do come with your system. You can order them online or by calling Shoo-fly.
- The compression fitting threads do not need teflon tape.
- Do not pull the tubing tight between nozzles. Leave some slack in the line.

We have instructional videos online at www.shoo-fly.com/instructions/installing-nozzles

ASSEMBLY OF THE MASTER UNIT

The Shoo-Fly System consists of two parts: 1. The Drum 2. The Master Unit.

Start by unpacking the Drum and inventorying all parts. The Drum is the reservoir for the Shoo-fly insecticide.

Place the System near a grounded outlet and with easy access to a hose. Allow at least a 24" x 24" x 5 ft space. Ideal location is Feed or Tack room. Ground level is the most convenient.

Do not place outside where it will be exposed to the weather or sit in sun.

The Drum should be cleaned at least once a year, usually in the spring before first fill-up.

DRUM ASSEMBLY

Referring to figure below there is a half round bead on the Drum top. On the inside of this bead, drill a hole big enough to place a saw blade into. Cut inside of the bead all the way around and discard the inner piece of plastic. With a file smooth the raw cut edges. Before placing the Master Unit on the Drum, make sure there are no shavings or dirt inside the Drum.

ALWAYS keep the inside of the Drum clean and free of foreign matter.

Place the plastic ring that is left back on top of the drum. Lock the cut lid to the ridge of the drum using the metal band. This completes the Drum Assembly.

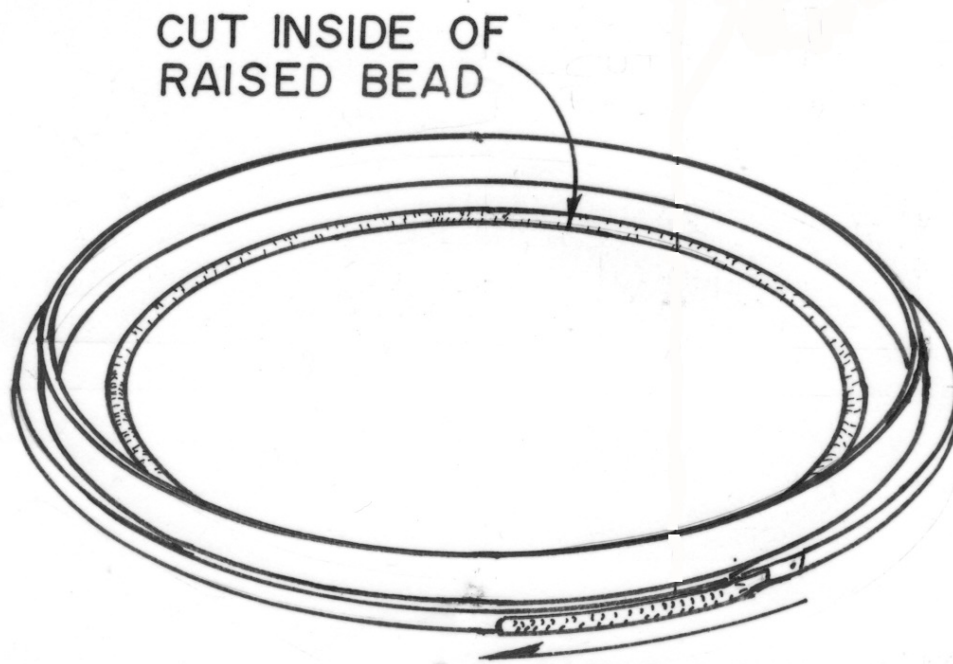

CHECK VALVE ASSEMBLY

The Pick-Up Check Valve with Filter and the Return Check Valve (Fig. 1 & 2, pg. 6) has to be attached to the fittings on the Pump.

1. Take the Tubing end of the Pick-Up Check Valve with Filter and feed it up through the larger of the two holes in the Lid. Place the 3/8" Insert into the Tubing and push into the 3/8s Nut, tighten with wrench. (Fig. 3, pg. 6).
2. Attach the Return Check Valve in the same manner. Feed the 1/4" Tube up through the small hole in the Lid. Insert a 1/4" Insert into the cut end of the tubing, push into the nut on the Pressure Regulator Valve and tighten with a wrench. (Fig. 5, pg. 6).

This completes this phase of the Master Unit Assembly.

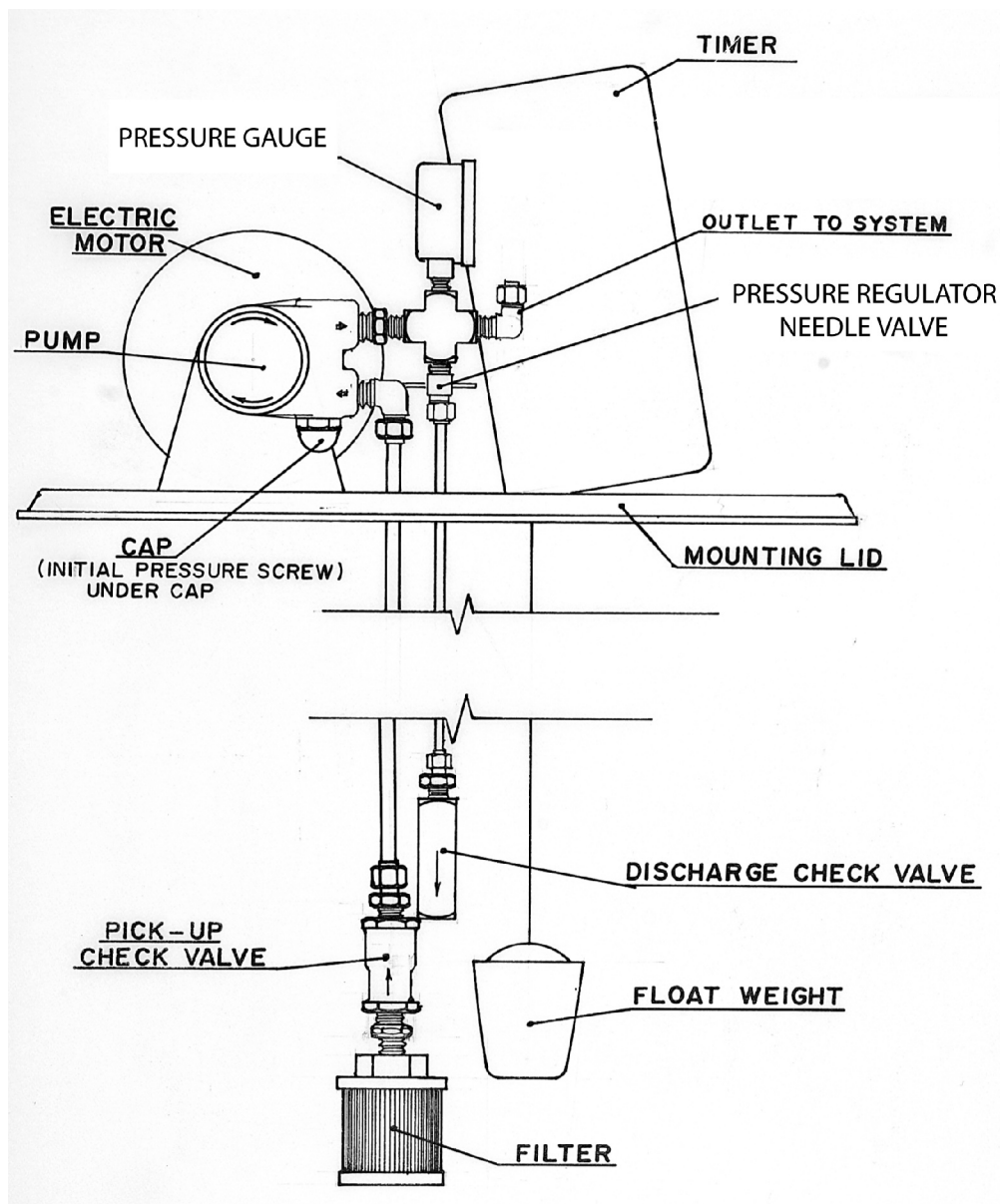

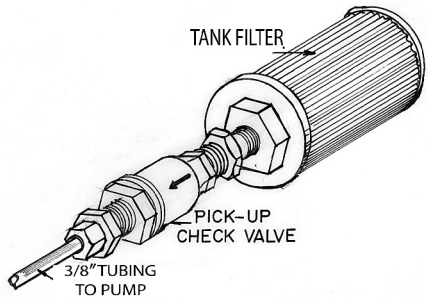

Fig. 1

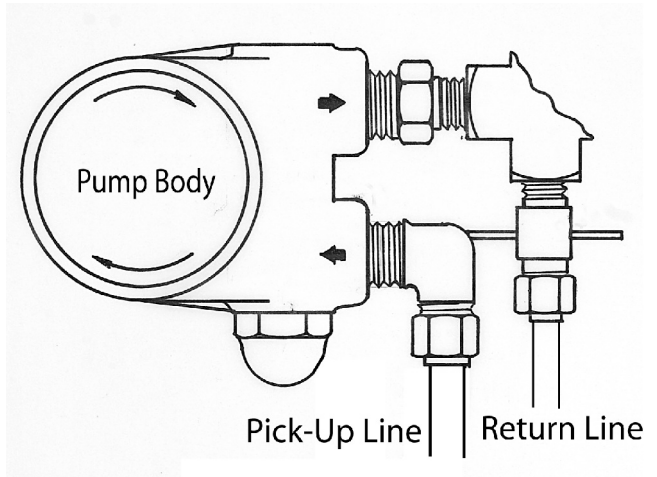

Fig 3

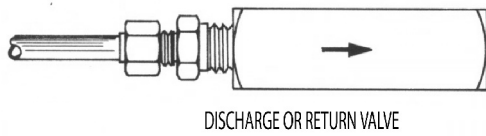

Fig 2

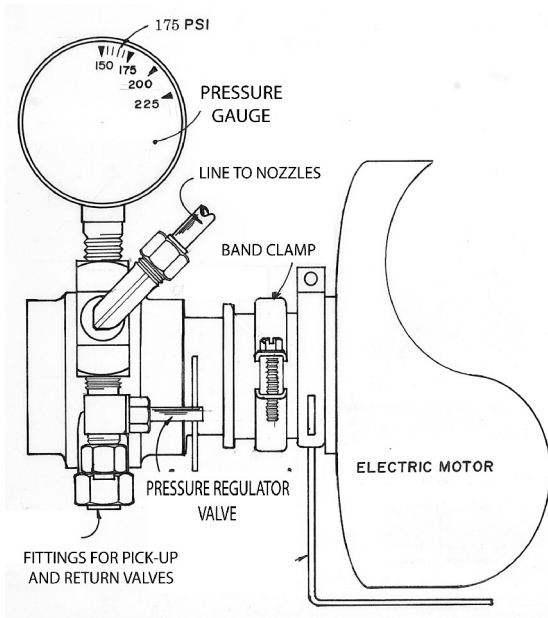

Fig 4

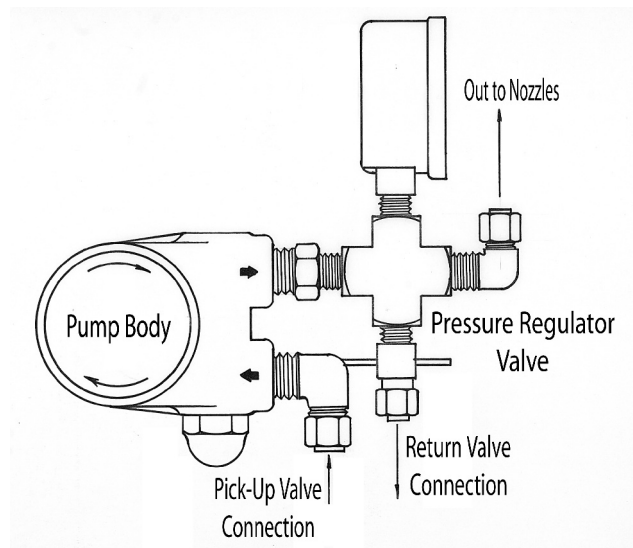

Fig 5

INSTALLATION OF NOZZLES

The optimum height for the Nozzle above the floor surface of the stall is 9 to 12 feet. Use any structure such as rafters, trusses, sub-floor, or electrical conduit to fasten tubing over the center of each stall. Figures below show the three ways to attach Nozzles. If a wooden structure or conduit is not available, then it is necessary to string plastic coated cable. Using plastic cable ties, mount Nozzles over the center of each stall.

Run the Tubing through out the barn over the stalls and back to the Master Unit. Pages 8 and 9 show different barn configurations and are discussed under each configuration.

- Do not pull tubing tight. Leave some slack in the lines. Also no sharp bends, use gentle sweeps for any turns or install brass elbows, available by calling or ordering online.

You will find Installation Videos at www.shoo-fly.com/instructions/installation-manual

NOTE: Nozzles should be installed offsetting any lights or fans. For special situations you can use Copper Extensions to put a nozzle below lights, fans or attached on the top of block walls. Call for more information.

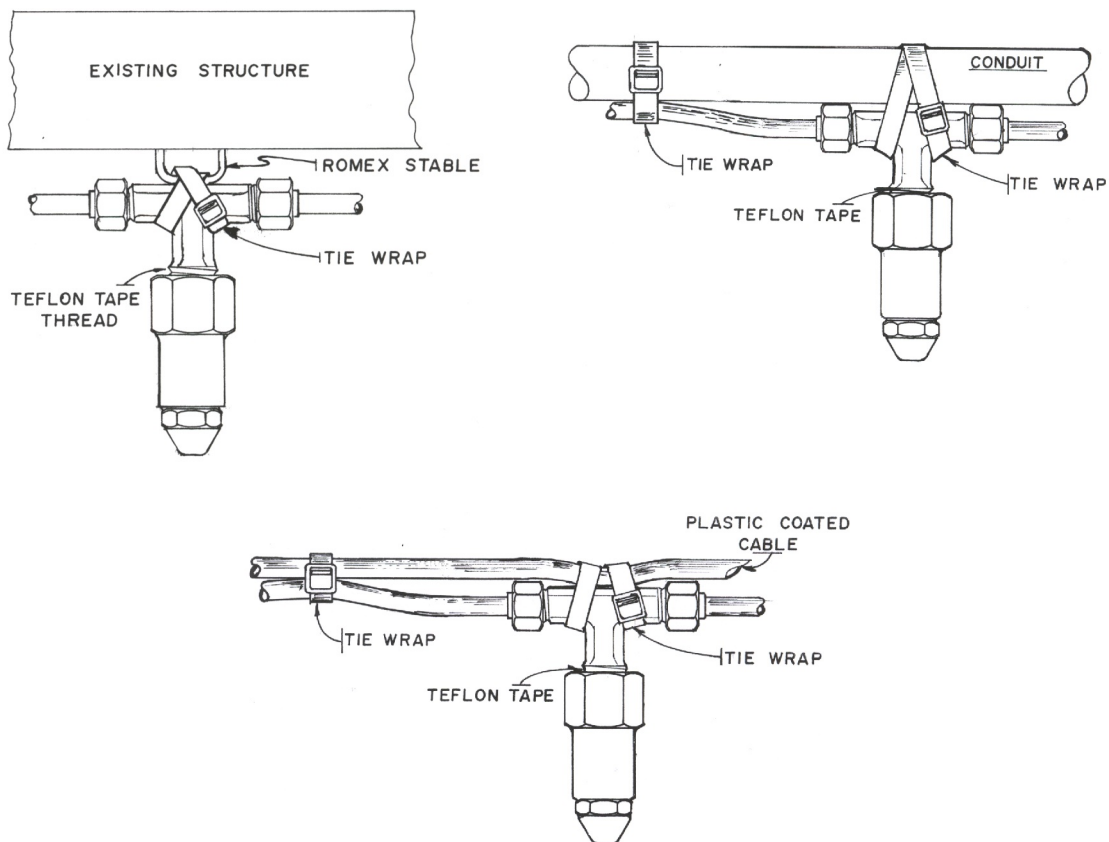

ROUTING OF TUBING CENTER AISLE BARN

Suggested pattern

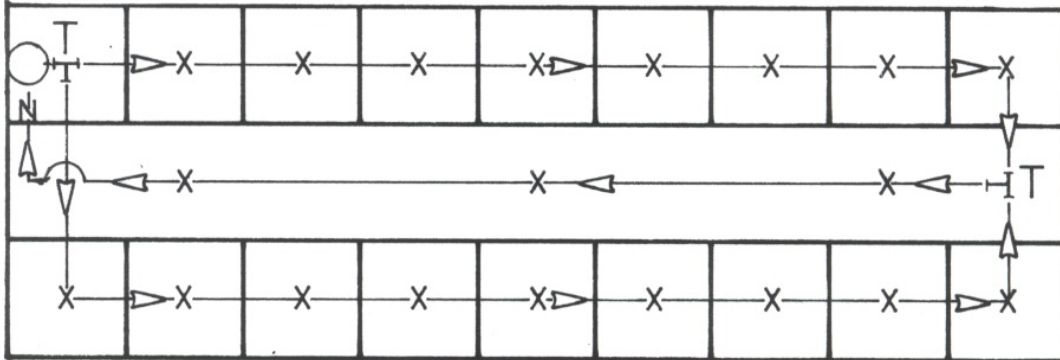

KEY:

- MASTER UNIT
- X NOZZLE ASSEMBLY
- N 1/4" NEEDLE (BLEEDER) VALVE
- T 1/4" UNION TEE
- ▷ DIRECTION OF FLOW

Loop the 1/4" Tubing above the center of the stalls and back to the beginning of the loop. Connect and fasten all Nozzles in their permanent location. Using 1/4" Tubing from the Master Unit connect into the loop with a Union Tee. This completes your main loop.

Next, insert a Union Tee into the center of the loop at the opposite end of the barn and route the Tubing along the center of the aisle, returning to the Master Unit. This line will not join into the loop near the Master Unit. Connect and fasten all Nozzles in their permanent location. Attach the Needle (bleeder) Valve approximately 18" from the Master Unit, adding a few feet of Tubing to the other side of the bleeder valve. The end of the Tubing should be a comfortable reach so that the Lid of the Master Unit can be lifted, the end of the Tubing dropped in, and all excess fluid can be bled back into the Drum.

Note: Smaller barns can have nozzles at the ends of the aisle where the tubing crosses over near the doorways and not put a line down the center aisle. If this is your plan you will not need the Union Tees.

- See page 10 for Final Setup.
- See pages 15 & 16 for larger barns. Barns with more than 40 Nozzles in one building should have 3/8" Tubing from the pump for about 10ft and reduce down to 1/4" tubing to feed the main lines.
- See pages 17-18 for more information.

ROUTING OF TUBING BACK TO BACK OR SHEDROW STALLS

Suggested Pattern

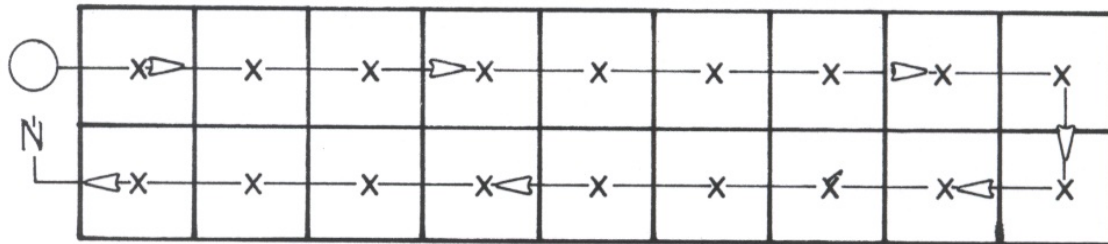

KEY:

- MASTER UNIT
- N 1/4" NEEDLE (BLEEDER) VALVE
- X NOZZLE ASSEMBLY
- ▷ DIRECTION OF FLOW

Loop the Tubing through the stalls and return to the Master Unit. Connect and fasten all Nozzles in their permanent location. Attach the Needle (bleeder) Valve approximately 18" from the end of the Tubing in a location that is comfortable to reach so that the Lid of the Master Unit can be lifted, the end of the Tubing dropped in, and all excess fluid can be bled back into the Drum.

Barns with 40 or more Nozzles:

Loop the Tubing over the stalls and return to Master Unit as described above. To finish the Tubing installation refer to Equalization of Pressure (pg. 16) and follow instructions given there.

NOTE: These are just a few suggestions for basic barn layouts. If you need any help you can email a sketch of the floor plan and we can suggest a tubing layout.

FINAL SET UP & OPERATION OF THE SYSTEM

Position the Drum in its permanent location. For the final set up, fill the drum about 1/3 with water. When setting the Master Unit on top of the Drum be sure the Check Valve Tubings and Float Weight line are hanging straight and not tangled. Place the Hood over the Master Unit, be sure the draw strings are facing front. Cut a small hole in a convenient location in the hood to feed the tubing into the pump to connect to the Nozzles. (Fig. 7, Pg 11) Connect the Tubing to the system at the elbow in front of the pump. A slit can be made anywhere, the material will not unravel.

After connecting the tubing to the pump be sure the Pressure Regulator Valve (Fig. 6, pg. 11), located below the Pressure Gauge, is closed.

Open the Shut-off Needle (Bleeder) Valve on the nozzle return line, to the full open position. Lift Master Unit Lid and place bleed line into the Drum. *If you are running Dead End lines you will not have a Bleeder Valve.*

Press the Override button to turn on the system (see page 14 for timer instructions, they can also be downloaded from our website).

- *For the Digital Timer, the override is a red button marked OVR to the left of the screen. You will need to program date, time & C1, before you can use the Override.*
- *For the Mechanical Timer, the override is the button on the outside of timer box on the left side. It will run for the set duration. Use the knob inside to set duration.*

Let system run until all of the air is bled from the lines. Once a uniform flow of insecticide is accomplished close the Bleeder Valve. *This may take a few times of pressing the Override depending on the number of nozzles you have.*

The pump should be 200-225 PSI while running, open the Pressure Regulator Valve on the pump (Fig 6, page 11), until the system shows **175** PSI. This is the *optimum operating pressure* of the system.

Check for any leaks, make sure the nozzles are all misting correctly. Now follow the fill up instructions and mix the insecticide in the drum.

Fit the Hood over the Master Unit and draw up the cord, this completes installation.

Note: The Pressure Gauge should read 200-225 PSI with the Flow Regulator Valve closed. If there is not 200-225 PSI turn the Pump off.

- Loosen the band clamp on the pump, tip it up to reach the adjustment screw that is located in the Cap on the bottom of the pump. (Fig. 3, pg 6)
- Adjust the screw in the cap on the bottom of the pump. Turn the screw, 1/4 turn clockwise, for each 25 lbs of pressure that the Pump is deficient.
- Make sure the clamp has been tightened before re-checking the pressure.

See the video at shoo-fly.com/instructions/trouble-shooting-pressure

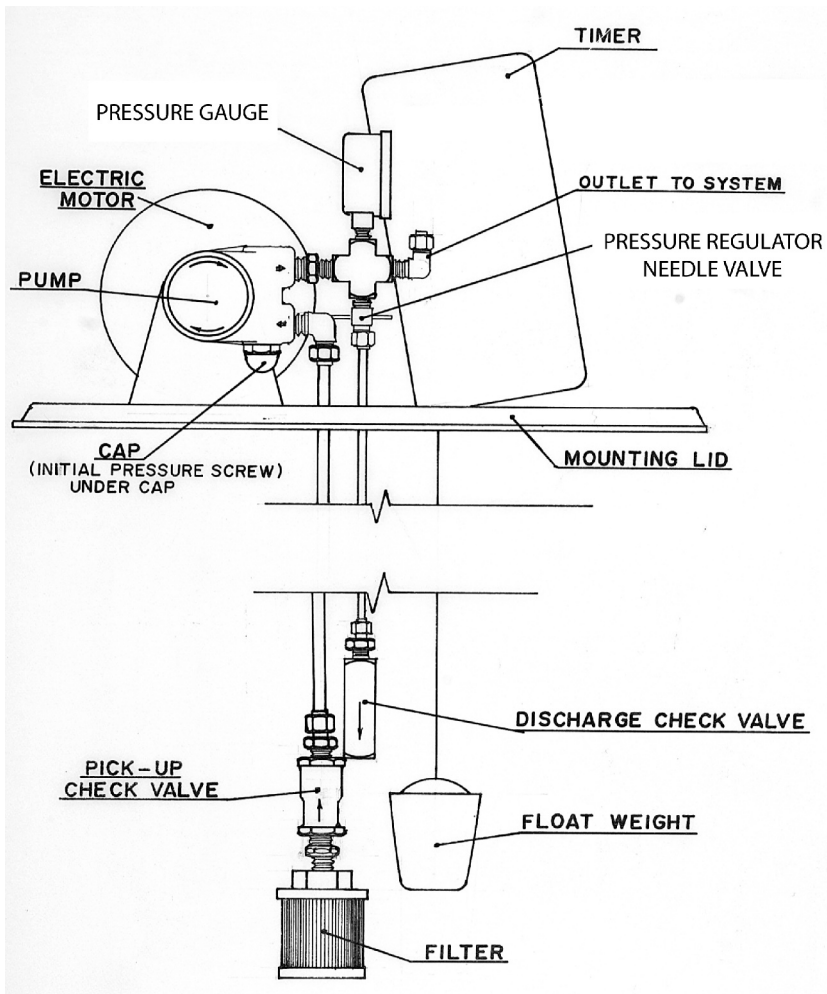

Fig. 6

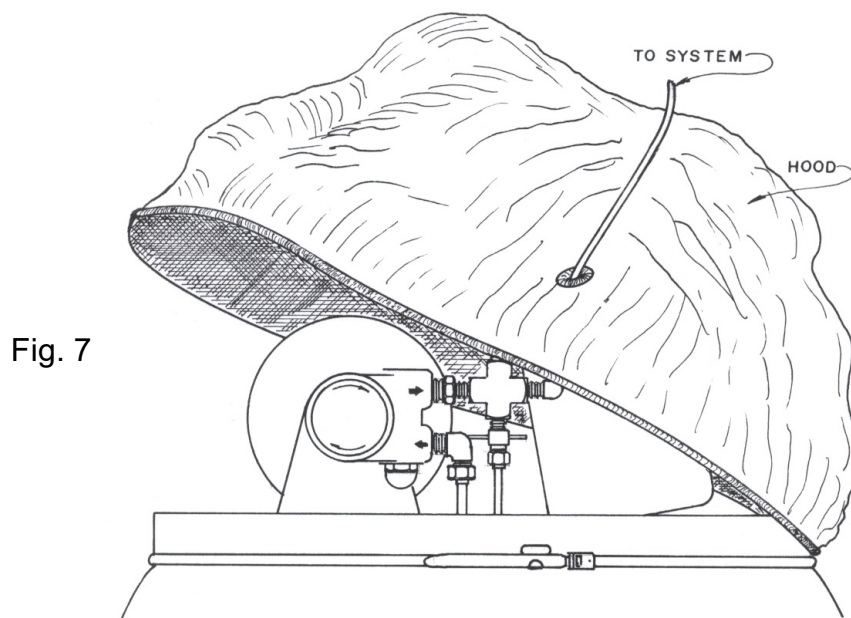

Fig. 7

FILLING OR REFILLING OF DRUM Concentrate I

Note: Always refer to instructions enclosed with each package of insecticide. Drum should be cleaned out at least once a year, depending on water quality.

1. READ LABEL !!!

2. SHAKE INSECTICIDE WELL! Use one gallon of Concentrate I diluted in 39 to 55 gallons of water, depending upon the difficulty of insect control. The average use is one gallon of Concentrate 1 to 54 gallons of water for a total of 55 gallons of ready-to-use insecticide. Most drums can hold up to 63 gallons of fluid, so be careful **not** to fill the drum higher than 8-10 inches from the lid. **DO NOT OVER DILUTE!**

3. Unplug the Master Unit.

4. Remove the Filter and clean it, then replace it finger tight. Examine the interior of the Drum for cleanliness. If the interior of the Drum appears to be dirty or has any residue build-up it is recommended that the Drum be taken outside and washed with bleach or a chlorine solution. Be sure to rinse the Drum before refilling. This procedure should be done at least once a year.

5. Place **clean** water hose inside the Drum with the nozzle at the **bottom** (to prevent foaming of insecticide), and fill the Drum 1/3 full with fresh water. **Slowly** add insecticide to the water while filling the second 1/3 of the Drum. Do not add insecticide too quickly or the insecticide will gel and then have to be mixed with a paddle.

6. Rinse the empty insecticide container 3-5 times until it rinses clear, pouring the rinse water into the Drum. Do this while filling the last 1/3 of the Drum.

7. Replace the Lid, plug in the machine and reset the Timer if need to.

NOTE:

For customers with hard water it has been found that adding ½ to 1 gallon of white vinegar will help balance the PH and you will get better performance from your insecticide and the equipment, less nozzle plugging and a smother mixture of insecticide. Vinegar may be added in the water before the insecticide.

We also have a H2O filter that fits on your hose with a 1 Micron filter. This will filter out particles that can plug up the nozzles. Call the office for more information or check on our website shoo-fly.com/shop/water-filter.

If your well has high bacteria you can add either ½ gallon of bleach or [Agrisyn](#) to cut down on the slim that builds up from the water and slows any break down of the insecticide.

You can also watch the video on our site shoo-fly.com/instructions/refill-your-drum

FILLING OR REFILLING OF DRUM **Livestock & Poultry w/ PBO**

Note: Always refer to instructions enclosed with each package of insecticide. Drum should be cleaned out at least once a year, depending on water quality.

1. READ LABEL !!!

VERY IMPORTANT: Add Livestock & Poultry **first**
Add PBO Concentrate **second**.

2. SHAKE INSECTICIDE WELL! Use 64 ounces of Livestock & Poultry Concentrate and 32 ounces of PBO Concentrate diluted in 40 to 54 gallons of water, depending on difficulty of insect control. Most drums can hold up to 63 gallons so be careful not to fill closer than 8 inches from the Lid. **DO NOT OVER DILUTE!**

3. Unplug the Master Unit.

4. Remove the Filter and clean it, then replace finger tight. Examine the interior of the Drum for cleanliness. If the interior of the Drum appears to be dirty or has any residue build-up it is recommended that the Drum be taken outside and washed with a strong bleach or chlorine solution. Be **sure** to rinse all detergents and bleach from the Drum before refilling. This procedure should be performed at least once a year.

5. Place **clean** water hose inside the Drum with the nozzle at the **bottom**, and fill the Drum 1/3 full with fresh water. While filling the **second** 1/3 of the Drum **slowly** add Livestock & Poultry Concentrate to the water. Rinse the empty insecticide container 3-5 times until it rinses clear, pouring the rinse water into the Drum.

Next, slowly add PBO Concentrate to the water. Do not add insecticide too quickly. Rinse the empty insecticide container as above, pouring the rinse water into the Drum. Finish filling the last 1/3 of the Drum with water, to no more than 8 inches from the top of the Lid.

6. Replace the Lid, plug in the machine and set the Timer.

NOTE:

For customers with hard water it has been found that adding ½ to 1 gallon of white vinegar will help balance the PH and you will get better performance from your insecticide and the equipment, less nozzle plugging and a smother mixture of insecticide. Vinegar may be added in the water before the insecticide.

We have a H2O filter that fits on your hose with a 1 Micron filter. This will filter out particles that can plug up the nozzles. Call the office for more information or check on our website shoo-fly.com/shop/water-filter.

If your well has high bacteria you can add either ½ gallon of bleach or [Agrisyn](#) to cut down on the slim that builds up from the water and slows any break down of the insecticide.

You can also watch the video on our site shoo-fly.com/instructions/refill-your-drum

TORK DIGITAL TIMER:

A few items for you to understand before we begin. These will become more familiar to you later as we get into programming the digital timer.

You will need to program your timer with two vital pieces of information:

A **CYCLE** is the length of TIME (duration) you want your unit to run (spray). It is measured from 1 to 99 seconds. There are TWO **CYCLES**, labeled **C₁** and **C₂**. Please note that you may choose to use only **C₁** or only **C₂** for each event.

An **EVENT** is any time your unit is scheduled to begin running the Cycle. An **EVENT** will last only as long as the number of seconds you have entered into either **C₁** or **C₂**. You can enter up to 20 **EVENTS** as needed. They will be listed in sequence as 01, 02, 03, etc.. and will be seen on the immediate **RIGHT** of the event time you scheduled your unit to begin running the cycle. Every **EVENT** has to be paired with either **C₁** or **C₂**, never OFF.

TIP: The time that you set for each **EVENT** to occur does NOT have to be in order. For example, suppose you want the **EVENT** to occur at 8:00 AM, 11:00 AM, 2:00 PM and 5:00PM. You missed 2:00 PM when programming your events. You may add 2:00 PM **AFTER** you have already input 5:00 PM. The event will still run in real time.

TIP: Watch our "How To" video shoo-fly.com/instructions/digital-timer

TIP: Once you have entered information, you can use the **DEL/PREV** button to go backward. For example, if you accidentally entered 28 for the date of the month and you wanted 26, press **DEL/PREV** button twice to go backward to 26. If you entered 76 seconds and wanted only 70, press **DEL/PREV** six times to go back to 70.

KEY FUNCTIONS:

Unit should be programmed with AC power on. Do not program on super cap back up power.

Mode: Press to go to the next mode.

Enter: Press to save current entry.

OVR/PERMANENT:

- a. Press in regular time mode to act as manual override for C_1 duration.

DEL/PREV:

- a. Press to delete the displayed entry.
- b. Press to gradually decrease the last selected entry.

HOUR/MONTH:

- a. Press to set hour in CLK (clock) mode and the SCH (schedule) mode.
- b. Press to set month in the DATE mode and DST (Daylight Savings Time) mode.

MINUTE/DATE:

- a. Press to set minutes in CLK (clock) mode and the SCH (schedule) mode.
- b. Press to set date in the DATE mode.

DAY/YEAR:

- a. Press to set the year in the DATE mode.
- b. Press to select the desired day of the week in the DST (Daylight Savings Time) mode.

EVENT:

- a. Press to select OFF/ C_1 / C_2 in the schedule.

ENTER:

- a. Press to save the displayed information into memory. Information will not be saved until the ENTER key is pressed.

NOTE: During settings, each press of the key will advance one number. For rapid advance hold key in.

SETTING THE TIMER

Unit must be plugged into AC power to set the timer. When you plug the unit in allow 1-2 minutes for the super cap to charge. You should see **d9 100** and **r – 5 1 60**. If the screen stays blank, hit **ENTER**, if the screen stays blank hit the recessed reset button located to the right of the **EVENT** button. To hit the reset button you will need something small like the end of a paperclip, hold for 2 seconds to reset. When these symbols do appear, they will flash and you will see a blinking 12 Hour. Here is your option to use a conventional 12 hour clock or military 24 hour clock. If you want a 12 hour clock, hit **ENTER**. If you want military time, press **HOUR/MONTH** button once and 24 hour will appear. Press it again and 12 hour will appear. Press **ENTER** when ready.

TIP: If the timer has not been totally cleared, a flashing 12 HOUR screen can appear. That is OK. Press **HOUR/MONTH** for either 12 hour or 24 hour clock. Press **ENTER**.

The screen will automatically change to the next mode: **Setting Clock**

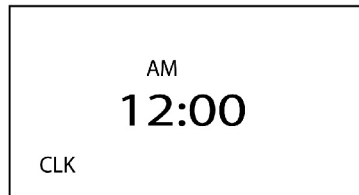

Use the **HOUR/MONTH**, **MIN/DATE** buttons to set the correct time. Be aware of AM and PM if using conventional time (12 hour clock). Once an hour or minute is input, you may use the **DEL/PREV** to go backward if you overshoot. When you have the correct time, AM or PM, Hour and minute. Press **ENTER**.

The screen will automatically change to the next mode: **Setting the Date**

SETTING THE DATE



Program the month, day and year using the **HOUR/MONTH**, **MIN/DATE** and **SEC/DAY/YEAR** buttons. Make sure the year is correct, it will affect what day of the week, abbreviated, appears at the top of the screen.

Press **ENTER**.

The screen will automatically change to the next mode: **Setting Daylight Savings Time**

SETTING DAYLIGHT SAVINGS TIME



If you want Daylight Savings Time press **ENTER**. If you do NOT want Daylight Savings Time, press **DEL/PREV**. It will change from ON to OFF. Press **ENTER**.

The screen will automatically change to the next mode: **Set Cycle Duration**

Before setting cycle durations, record duration lengths in seconds (C_1 or C_2) and times (Events) you want your unit to run. See **example** in chart below.

Duration Settings: C_1 60 seconds C_2 40 seconds

Event	Time	Choose One	Event	Time	Choose One
01	08:10 AM	C_1	05	10:00 PM	C_2
02	11:00 AM	C_1	06	03:00 AM	C_2
03	02:00 PM	C_1	07	_____	C_1 or C_2
04	05:00 PM	C_1	08	_____	C_1 or C_2

SET CYCLE DURATION (C_1 and C_2)

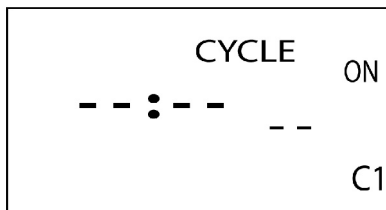

Using the **SEC/DAY** button, set the number of seconds you want for C_1 . Use the **DEL/PREV** to go backward if you overshoot. If there is a number of seconds shown here already, you may change it or keep it. Press **ENTER** the screen will display C_2

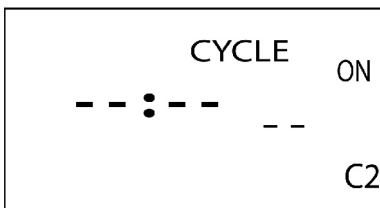

Using the **SEC/DAY** button, set the number of seconds you want C_2 . Use the **DEL/PREV** to go backward if you overshoot. If there is a number of seconds shown here already, you may change it or keep it. Press **ENTER** and the screen will display C_1 again. By pressing **ENTER** you will cycle back and forth between C_1 and C_2 .

Press **MODE** The screen will automatically change to: **Schedule Event 01**

SCHEDULE EVENT 01

SCHEDULING EVENT 01:

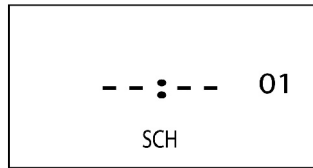

01 First Event

EVENT (01) Enter the time using the HOUR and MIN buttons to tell the unit when to come on. Be aware of AM and PM. (If there is a time already here, you may keep it or change it using the **HOUR/MONTH** and **MIN/DATE** buttons.)

The screen will change to:



08:10 AM time of 01 First Event

After you enter the time press the **EVENT** button. You may choose to use either Cycle: **C₁** or **C₂**. Press **EVENT** button until you see the Cycle you want on left. **DO NOT USE "OFF"**

The screen should look like this:



C1 is chosen, either C₁ or C₂ can be used.

Press **ENTER** button to save the event. The screen will automatically change to:
Schedule Event 02

SCHEDULE EVENT 02

SCHEDULING EVENT 02:

__ : __ 02
SCH

02: Second Event

EVENT (02) Enter the time using the HOUR and MIN buttons to tell the unit when to come on. Be aware of AM and PM. (If there is a time already here, you may keep it or change it using the **HOUR/MONTH** and **MIN/DATE** buttons.)

The screen will change to:

AM
OFF 11:00 02
SCH

11:00 AM time of 02 Second Event

After you enter the time press the **EVENT** button. You may choose to use either Cycle: **C₁** or **C₂**. Press **EVENT** button until you see the Cycle you want on left. **DO NOT USE "OFF"**

The screen should look like this:

AM	CYCLE
C 1 11:00 02	
SCH	

C₁ is chosen, either C₁ or C₂ can be used

Press **ENTER** button to save the event. The screen will automatically change to:
Schedule Event 03

SCHEDULE EVENT 03

SCHEDULING EVENT 03:

__ : __ 03
SCH

03: Third Event

EVENT (03) Enter the time using the HOUR and MIN buttons to tell the unit when to come on. Be aware of AM and PM. (If there is a time already here, you may keep it or change it using the **HOUR/MONTH** and **MIN/DATE** buttons.)

The screen will change to:

	PM	
OFF	02:00	03
	SCH	

02:00 PM time of 03 Third Event

After you enter the time press the **EVENT** button. You may choose to use either Cycle: **C₁** or **C₂**. Press **EVENT** button until you see the Cycle you want on left. **DO NOT USE "OFF"**

The should look like this:

	PM	CYCLE
C1	02:00	03
	SCH	

C₁ is chosen, either C₁ or C₂ can be used.

Press **ENTER** button to save the event. The screen will automatically change to:
Schedule Event 04

SCHEDULE EVENT 04

SCHEDULING EVENT 04:

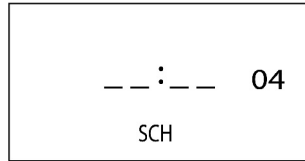

04: Fourth Event

EVENT (04) Enter the time using the HOUR and MIN buttons to tell the unit when to come on. Be aware of AM and PM. (If there is a time already here, you may keep it or change it using the **HOUR/MONTH** and **MIN/DATE** buttons.)

The screen will change to:



05:00 PM time of 04 Fourth Event

After you enter the time press the **EVENT** button. You may choose to use either Cycle: **C₁** or **C₂**. Press **EVENT** button until you see the Cycle you want on left. **DO NOT USE "OFF"**

The screen should look like this:



C₁ is chosen, either C₁ or C₂ can be used.

Press **ENTER** button to save the event. The screen will automatically change to:
Schedule Event 05

Repeat these steps for **SCHEDULING EVENTS**

After you have entered the last EVENT, press **ENTER**, then press **MODE** and your unit is set up.

You should see "**FLASH**" briefly on the screen.

For example if your **CURRENT TIME** is 11:15 and 20 seconds AM on Friday your display should look like this:

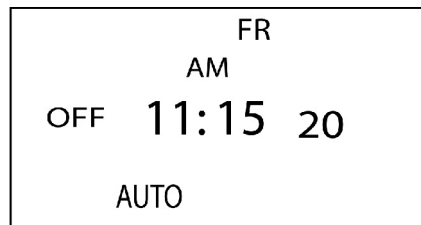

- 11:15 20 is your current time.
- Current DAY, *Friday*, shows at the top.
- AM will also show.

NOTE that display also shows *OFF*. It will display either **C₁** or **C₂** when it begins running.

Congratulations, you have set up your Digital TORK timer.

Additional Notes:

TO ERASE DATE AND TIME ONLY

Pressing the recessed **RESET** button will allow you to erase the time and date settings. It will not change your **C₁** or **C₂** duration or scheduled **EVENTS**. The reset button is located in the hole to the right of the **EVENT** button. You will need something like a straightened paper clip to press that button.

TO ERASE EVERYTHING AND START FROM THE BEGINNING:

When the time of day screen is showing, you can take the following action:

To clear the clock, **C₁**, **C₂**, and the scheduled **EVENTS**, press **ENTER**. You will see the screen below.



Hitting **EVENT** will change it to this:



Press **ENTER**, erase everything. You will see 12 HOUR flashing start over.

TO REVIEW YOUR INPUTS

Please note that any of the information that is displayed can be changed during this process.
You **MUST** press **ENTER** to store any **CHANGES**.

Your display should look like this:

```
      FR
    AM
OFF  XX:XX  XX
      AUTO
```

Your current time, day (FR), AM or PM,
OFF and AUTO

Press MODE. Your display will look like this:

```
      FR
    AM
OFF  XX:XX  XX
      MAN
```

This system **will not** operate in this mode (**MAN**)

Press MODE again.

You will see your CLK time. You can adjust the time. Hit ENTER to lock it in.

Press MODE again.

You will see your DATE appear. You can adjust the date. Hit ENTER to lock it in.

Press MODE again.

dSt will appear.

Press MODE again.

See C₁ time comes up. You may change this using the Second button, be sure to Hit ENTER to lock it in.

Hit ENTER to toggle between C₁ and C₂.

See C₂ appear. You may change this using the Second button, be sure to Hit ENTER to lock it in.

Press MODE again.

See EVENT 01 appear. You may change this, but be sure to press ENTER to lock it in.

Hit ENTER to advance to/edit next Event.

See EVENT 02 appear. You may change this, but be sure to press ENTER to lock it in.

Hit ENTER to advance to/edit next Event.

EVENT 03 will appear.

Hit ENTER to advance to/edit next Event

EVENT 04 will appear. You may change this, but be sure to press ENTER to lock it in.
Etc. When ALL events have come up and a blank EVENT shows, then

Press MODE again You will be back to correct time of day.

WINTERIZING THE SYSTEM

Prolonged freezing temperatures in harsh climates may cause damage to the Nozzles and the Pump. The last fill up should be planned so as to run out of insecticide before freezing temperatures arrive, no more than 5 gallons of insecticide should remain in the system.

For a video on how to Winterize go to shoo-fly.com/instructions/winterizing

Using a non-toxic anti-freeze (such as the type sold for use in the water lines of recreational vehicles) add this to the remaining insecticide. Check the anti-freeze label for the dilution rate.

- Open the Shut-off (bleeder) Valve on the end of the loop coming back to the Master Unit and turn on the Unit using the Over-ride button.
- Let insecticide flow into the Master Unit until you see the change of color and you know the anti-freeze is throughout the Tubing and Nozzles.
- Close the Shut-off (bleeder) Valve and pressurize the system for about 10 seconds. This should be sufficient to get the anti-freeze into the Nozzle Tips.

The system can then be unplugged for the winter.

This is the safest way to prevent damage that can occur when the System is exposed to freezing temps. Even if the Master Unit is in a room where it may not freeze but the tubing and nozzles are exposed to the cold and fluid left in them can freeze and crack the tubing or brass parts. It also protects the internal pump parts from damage and the valves in the drum.

When the fly season begins next spring, the anti-freeze should be bled out of the lines and the Drum cleaned thoroughly.

We recommend cleaning the system with a strong bleach or chlorine solution and a scrub brush. The system should then be flushed with fresh water and vinegar and refilled with insecticide at the beginning of the season.

See "Filling Or Refilling Of Drum" pages 12 & 12a or see the video at shoo-fly.com/instructions/refill-your-drum

Note:

- **Do Not** blow out the system with air. You could miss liquid in the lines or pump that could cause damage.

LARGE BARNS

For large barns use the diagrams below to guide you in routing your tubing to get the optimum spray to each nozzle.

See page 16 for information on equalizing of pressure

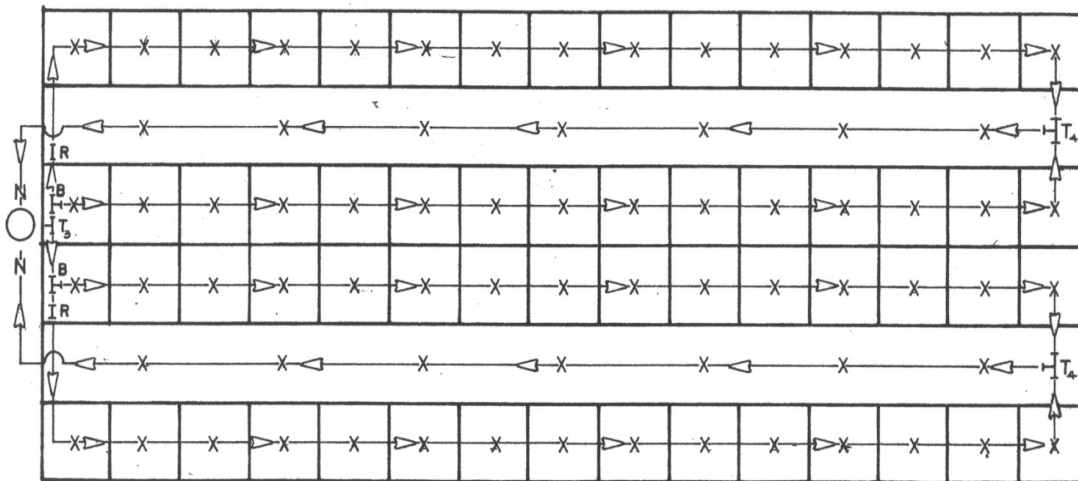

KEY:

- MASTER UNIT
- X NOZZLE ASSEMBLY
- T₃ 3/8" UNION TEE
- T₄ 1/4" UNION
- N NEEDLE (BLEEDER) VALVE
- B 3/8" FEM. CONNECTOR TO 1/4" BRANCH TEE
- R 3/8" TO 1/4" REDUCER
- ▷ DIRECTION OF FLOW

Some middle sized barns with 30-40 nozzles, may only need a 3/8" tubing out of the pump feeding the nozzles. For these barns you will need change the 1/4" elbow to a 3/8" elbow on the pump. Using about 10ft 3/8" tubing to go to the 3/8" Union and a 3/8" to 1/4" reducer to the main nozzle tubing. If you are not sure you can email us a drawing and we can help with the layout.

EQUALIZATION OF PRESSURE

When operating 40 or more Nozzles, it is necessary to equalize pressure on both sides of the loop. To do this an Equalization Valve is installed into the lines. A suggested set-up for this is described below.

Steps to install an EQ Valve, as shown below (Fig 1). Pick a convenient location prior to the first Nozzle.

1. Run 3/8" Tubing from the out going elbow on the pump to the 3/8s fitting on the EQ Valve. Connect a short piece of 3/8s to the other side of the Tee then connect a 3/8" to 1/4" Reducer.
2. Connect 1/4" Tubing to the reducer and run the tubing to the first Nozzle and around the barn.
3. From the last Nozzle continue the 1/4" tubing back to the EQ Valve. At this point connect the 1/4" tubing to the 1/4" Tee on the EQ Valve.
4. On the other side of the Tee attach 1/4" tubing heading back to the Master Unit. Put a Shut-off (bleeder) Valve on this line and attach another 18" length of 1/4" Tubing on the other side. This goes into the Drum and is used for bleeding purposes only.
5. To bleed the system close the EQ Needle (bleeder) Valve and open the Shut-off Needle (bleeder) Valve near the drum on the return line.
6. Use the Over Ride and run the Master Unit until all air has been bled from the lines. Once a uniform flow of fluid has been accomplished, close the Shut-off Needle (bleeder) Valve on the return line and open the Pressure Regulator valve until you get 175 PSI on the Gauge.
7. Open the EQ Needle (bleeder) Valve. This completes the equalization of pressure.

The EQ Valve comes to you completely assembled as one piece with a 3/8 Tee, 3/8 to 1/4 reducer, Needle valve, & a 1/4 Tee. It is installed prior to the first nozzles as described above. The return line also attaches to the this valve and then returns back to the drum as described.

